

## CURRENT MODE PWM+PFM CONTROLLER WITH BUILT-IN HIGH VOLTAGE MOSFET

### DESCRIPTION

SD686X is current mode PWM+PFM controller with built-in high-voltage MOSFET used for SWPS, with low standby power and low start current for power switch. In standby mode, the circuit enters burst mode to reduce the standby power dissipation. The switch frequency is 25~67KHz with jitter frequency for low EMI.

Built-in peak current compensation circuit makes the limit output power stable even with different input AC voltage. Limit output power can be adjusted through the resistor. Maximum peak current compensation during power-on reduces pressure on transformer to avoid saturation, the peak current compensation will decrease for balance after power-on.

It integrates various protections such as undervoltage lockout, overvoltage protection, overload protection, lead edge blanking, primary winding overcurrent protection and thermal shutdown. The circuit will restart until normal if protection occurs.

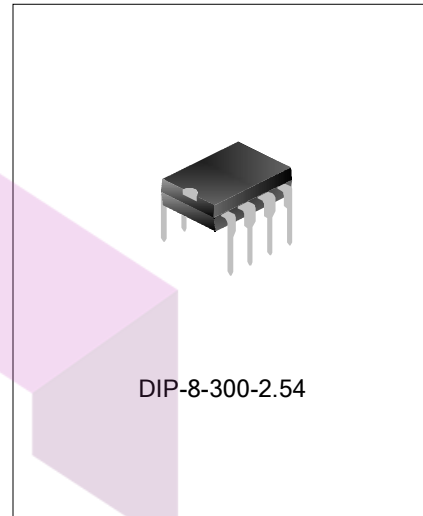

### APPLICATIONS

\* SWPS

### FEATURES

- \* Energy Star 2.0 standard
- \* Lower start-up current (3 $\mu$ A)
- \* Various switching frequency following load for the higher efficiency
- \* Frequency jitter for low EMI
- \* Overvoltage, overcurrent, overload and over temperature protections.
- \* Adjustable limit output power
- \* Undervoltage lockout
- \* Built-in high voltage MOSFET
- \* Auto restart mode
- \* Peak current compensation
- \* Maximum peak current compensation for initialization
- \* Burst mode
- \* Cycle by cycle current limit

تهیه و توزیع قطعات الکترونیک

**ORDERING INFORMATION**

Part No.	Package	Marking	Material	Package Type
SD6860	DIP-8-300-2.54	SD6860	Pb free	Tube
SD6861		SD6861	Pb free	Tube
SD6862		SD6862	Pb free	Tube
SD6863		SD6863	Pb free	Tube
SD6864		SD6864	Pb free	Tube

**TYPICAL OUPUT POWER CAPABILITY**

Part No.	190~265V		85~265V	
	Adapter	Open	Adapter	Open
SD6860P65K67	7W	9W	5W	7.2W
SD6861P65K67	10W	14W	8W	12W
SD6862P65K67	12W	17W	10W	14W
SD6863P65K67	14W	19W	12W	15W
SD6864P65K67	16W	21W	14W	18W

**BLOCK DIAGRAM**

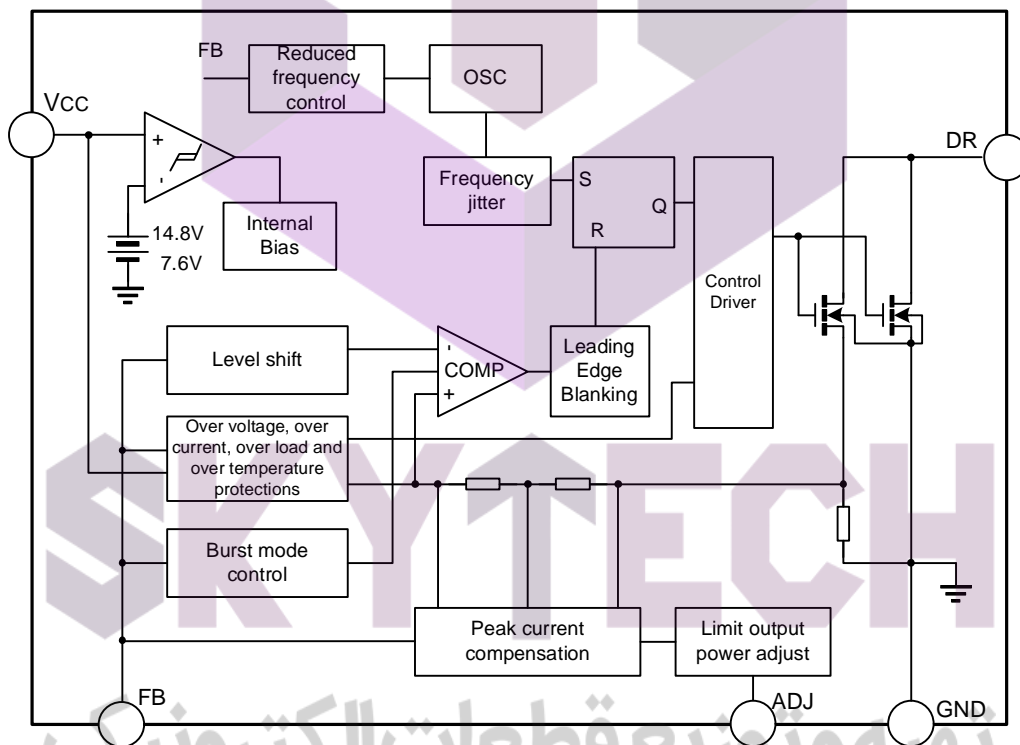

**ABSOLUTE MAXIMUM RATING**

Characteristics		Symbol	Rating	Unit
Drain-Gate Voltage (R <sub>GS</sub> =1MΩ)		V <sub>DGR</sub>	650	V
Gate-Source (GND) Voltage		V <sub>GS</sub>	±30	V
Drain Current Pulse <small>note1</small>	SD6860	I <sub>DM</sub>	4	A
	SD6861		6	
	SD6862		8	
	SD6863		11	
	SD6864		14	
Continuous Drain Current (T <sub>amb</sub> =25°C)	SD6860	I <sub>D</sub>	1	A
	SD6861		1.5	
	SD6862		2	
	SD6863		3	
	SD6864		4	
Signal Pulse Avalanche Energy <sup>note2</sup>	SD6860	EAS	15	mJ
	SD6861		30	
	SD6862		68	
	SD6863		140	
	SD6864		200	
Power Supply Voltage		V <sub>CC,MAX</sub>	28	V
Feedback input voltage		V <sub>FB</sub>	-0.3~8	V
Limit output power voltage		V <sub>ADJ</sub>	-0.3~8	V
Total Power Dissipation	P <sub>D</sub>		1.5	W
	Darting		0.017	W/°C
Operating Junction Temperature		T <sub>J</sub>	+170	°C
Operating Temperature		T <sub>amb</sub>	-25~+85	°C
Storage Temperature		T <sub>STG</sub>	-55~+150	°C

Note: 1. Pulse width is limited by maximum junction temperature;

2. L=51mH, T<sub>J</sub>=25°C(start).

**ELECTRICAL CHARACTERISTICS** (for MOSFET, unless otherwise specified, T<sub>amb</sub>=25°C)

Characteristics		Symbol	Test conditions	Min.	Typ.	Max.	Unit
Drain-Source Breakdown Voltage		BV <sub>DSS</sub>	V <sub>GS</sub> =0V, I <sub>D</sub> =50μA	650	--	--	V
Zero Gate Voltage Drain Current		I <sub>DSS</sub>	V <sub>DS</sub> =650V, V <sub>GS</sub> =0V	--	--	50	μA
			V <sub>DS</sub> =480V, V <sub>GS</sub> =0V T <sub>amb</sub> =125°C	--	--	200	μA
Static Drain-Source On Resistance	SD6860	R <sub>DS(ON)</sub>	V <sub>GS</sub> =10V, I <sub>D</sub> =0.5A	--	14.0	16.8	Ω
	SD6861			--	8.0	9.6	
	SD6862			--	5.0	6.0	
	SD6863			--	4.0	4.8	
	SD6864			--	3.0	3.6	

Characteristics		Symbol	Test conditions	Min.	Typ.	Max.	Unit
Input Capacitance	SD6860	C <sub>ISS</sub>	V <sub>GS</sub> =0V, V <sub>DS</sub> =25V, f=1MHz	--	210	--	pF
	SD6861			--	250	--	
	SD6862			--	550	--	
	SD6863			--	640	--	
	SD6864			--	840	--	
Output Capacitance	SD6860	C <sub>OSS</sub>	V <sub>GS</sub> =0V, V <sub>DS</sub> =25V, f=1MHz	--	18	--	pF
	SD6861			--	25	--	
	SD6862			--	38	--	
	SD6863			--	40	--	
	SD6864			--	44	--	
Reverse Transfer Capacitance	SD6860	C <sub>RSS</sub>	V <sub>GS</sub> =0V, V <sub>DS</sub> =25V, f=1MHz	--	8	--	pF
	SD6861			--	10	--	
	SD6862			--	17	--	
	SD6863			--	30	--	
	SD6864			--	40	--	
Turn On Delay Time	SD6860	T <sub>D(ON)</sub>	V <sub>DD</sub> =0.5BV <sub>DSS</sub> , I <sub>D</sub> =25mA	--	10	--	ns
	SD6861			--	12	--	
	SD6862			--	20	--	
	SD6863			--	33	--	
	SD6864			--	40	--	
Rise Time	SD6860	T <sub>R</sub>	V <sub>DD</sub> =0.5BV <sub>DSS</sub> , I <sub>D</sub> =25mA	--	3	--	ns
	SD6861			--	4	--	
	SD6862			--	15	--	
	SD6863			--	19	--	
	SD6864			--	25	--	
Turn Off Delay Time	SD6860	T <sub>D(OFF)</sub>	V <sub>DD</sub> =0.5BV <sub>DSS</sub> , I <sub>D</sub> =25mA	--	27	--	ns
	SD6861			--	30	--	
	SD6862			--	55	--	
	SD6863			--	70	--	
	SD6864			--	90	--	
Fall Time	SD6860	T <sub>F</sub>	V <sub>DD</sub> =0.5BV <sub>DSS</sub> , I <sub>D</sub> =25mA	--	8	--	ns
	SD6861			--	10	--	
	SD6862			--	25	--	
	SD6863			--	32	--	
	SD6864			--	42	--	

**ELECTRICAL CHARACTERISTICS** (unless otherwise specified, V<sub>CC</sub>=12V, T<sub>amb</sub>=25°C)

Characteristics	Symbol	Test conditions	Min.	Typ.	Max.	Unit
<b>Undervoltage Section</b>						
Start Threshold Voltage	V <sub>START</sub>		14	14.8	16	V
Stop Threshold Voltage	V <sub>STOP</sub>		6.6	7.6	8.6	V

Characteristics		Symbol	Test conditions	Min.	Typ.	Max.	Unit
<b>Oscillator Section</b>							
Max. Oscillate Frequency	fOSCMAX	VFB=3V	61	67	73	KHz	
Min. Oscillate Frequency	fOSCMIN	VBURL<VFB<VBURH	20	25	30	KHz	
Frequency jitter	fMOD	Oscillate frequency is the maximum	--	±2.5	±3.5	KHz	
Frequency Change With Temperature	--	25°C≤Tamb≤+85°C	--	±5	±10	%	
Maximum Duty cycle	DMAX		72	77	82	%	
<b>Feedback Section</b>							
Feedback Source Current	IFB	VFB=0V, RADJ=0	0.8	0.9	1.0	mA	
Shutdown Feedback Voltage (over load protection)	VSD		3.8	4.3	4.8	V	
Shutdown Feedback Delay Time	TSD	FB is increased to 5V from 0V instantly	15		40	ms	
Shutdown Delay Current	IDELAY	VFB=5V	3	5.5	8	μA	
<b>Limit Output power</b>							
FB current 1	IFB1	VFB=0V, RADJ=100KΩ	0.60	0.69	0.78	mA	
Min. Resistor For Limit Output Power Adjust	RADJ	VFB=0V, FB current is decreased	14	20	28	KΩ	
<b>Current Limit</b>							
Peak Current Limit	SD6860	I <sub>OVER</sub>	Max. inductor current	0.53	0.60	0.67	A
	SD6861			0.67	0.75	0.83	
	SD6862			0.80	0.90	1.00	
	SD6863			1.10	1.20	1.30	
	SD6864			1.35	1.50	1.65	
<b>Burst mode</b>							
Burst Mode High Voltage	VBURH	FB voltage	0.40	0.50	0.60	V	
Burst Mode Low Voltage	VBURL	FB voltage	0.25	0.35	0.45	V	
<b>Protection Section</b>							
Overvoltage Protection	VOVP	VCC voltage	22	24	26	V	
Over temperature protection	TOTP		125	160	--	°C	
Quit over temperature protection	TOTU		80	100	120	°C	
Leading-edge Blanking Time	TLEB		350	650	--	ns	
<b>Total Standby Current</b>							
Start Current	ISTART	VCC increases from 0V to 12V	--	3	10	μA	
Quiescent Current	ISTATIC	VFB=0V	1.0	1.9	3.0	mA	
Operating Current	SD6860	I <sub>OP</sub>	VFB=3V	1.0	2.0	3.0	mA
	SD6861			1.0	2.0	3.0	
	SD6862			1.2	2.2	3.2	
	SD6863			1.2	2.2	3.2	
	SD6864			1.4	2.4	3.4	

## PIN CONFIGURATION

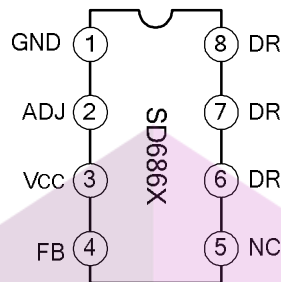

## PIN DESCRIPTION

Pin No.	Pin Name	I/O	Function description
1	GND	I	Ground
2	ADJ	I	ADJ pin
3	Vcc	I	Power supply pin
4	FB	I/O	Feedback input pin
5	NC	-	NC
6, 7, 8	DR	O	Drain pins.

## FUNCTION DESCRIPTION

SD686X is designed for off-line SMPS, consisting of high voltage MOSFET, optimized gate driver and current mode PWM+PFM controller which includes frequency oscillator and various protections such as undervoltage lockout, overvoltage protection and overload protection. Frequency jitter generated from oscillator is used to lower EMI. Burst mode is adopted during light load to lower standby power dissipation, and function of lead edge blanking eliminates the MOSFET error shutdown caused by interference through minimizing MOSFET turning on time. Peak current compensation reduces the pressure on transformer during circuit starts and output power limit can be adjusted by resistor through ADJ pin. Few peripheral components are needed for higher efficiency and higher reliability and it is suitable for flyback converter and forward converter.

### 1. Under Voltage Lockout and Self-Start

At the beginning, the capacitor connected to pin Vcc is charged via start resistor by high voltage AC and the circuit starts to work if voltage at Vcc is 14.8V. The output and FB source current are shutdown if there is any protection during normal operation and Vcc is decreased because of powering of auxiliary winding. The whole control circuit is shutdown if voltage at Vcc is 7.6V below to lower current dissipation and the capacitor is recharged for restarting.

تهیه و توزیع قطعات الکترونیک

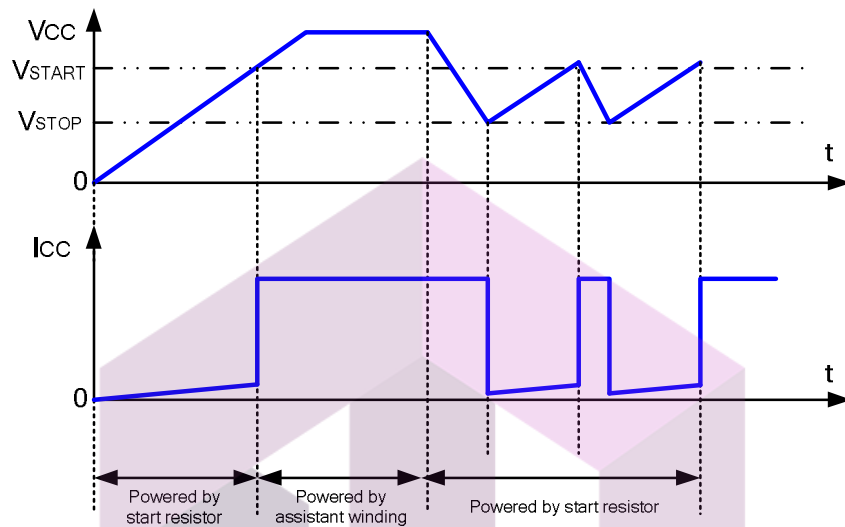

## 2. Frequency Jitter and reduced frequency mode

The oscillation frequency is kept changed for low EMI and decreasing radiation on one frequency. The oscillation frequency changes within a very small range to simplify EMI design. The rule of frequency changing (frequency center is 67KHz):  $\pm 2.5\text{KHz}$  change in 4ms, 64 frequency points in all.

For high efficiency, frequency is changed according to current output from FB pin. When FB current is above a certain value (different with different version) without limit output power adjust, frequency decrease from 67KHz to typ. 25KHz.

## 3. Peak current compensation and normalization

Generally, limit output power changes with different inputs. Limit output power is hold in this circuit because of peak current compensation. Larger peak current compensation for higher input AC voltage, it decreases to zero with light load and no peak current compensation in burse mode.

Maximum peak current compensation during power-on reduces pressure on transformer to avoid saturation, the peak current compensation will decrease for balance after power-on. The duration is decided by the load.

## 4. Limit output power adjust

Limit output power is adjusted by varying FB current through resistor RADJ adjust. When RADJ=0, no change in limit output power; when RADJ exceeds typ. 20K $\Omega$ , limit output power begins to be reduced.

## 5. Burst mode

Working in this mode to reduce power dissipation. It works normally when FB is 0.5V above, and during  $0.35\text{V} < \text{FB} < 0.5\text{V}$ , there are two different conditions: when FB changes from low to high, there is no action for switch and it is the same with condition of FB lower than 0.35V; the other is that FB changes form high to low, comparison value is increased for increasing turning on time to decrease switch loss. In this mode, switching frequency is down to 25KHz.

For this mode, during FB changes form high to low, the output voltage increases (increasing speed is decided by load) because of the high comparison value to decrease FB until it is 0.35V below; when  $\text{FB} < 0.35\text{V}$ , there is no action for switch and output voltage decrease (decreasing speed is also decided by load) to increase FB voltage.



FB voltage is 0.5V below with light load. This is repeated to decrease action of switch for lower power dissipation.

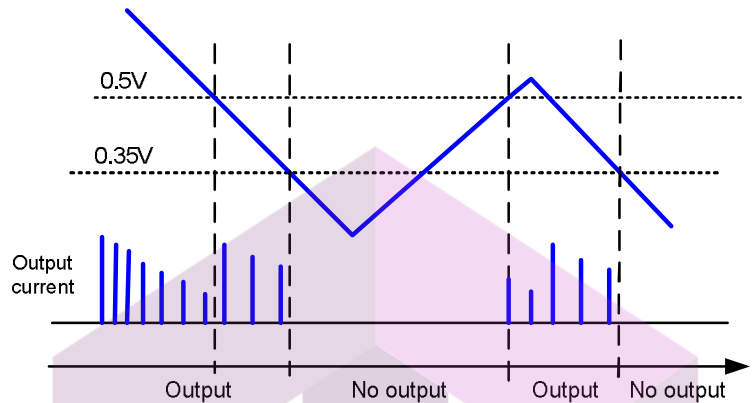

### 6. Leading Edge Blanking

For this current-controlled circuit, there is pulse peak current during the transient of switch turning on and there is an error operation if the current is sampled during this time. And leading edge blanking is adopted to eliminate this error operation. The output of PWM comparator is used for controlling shutdown after the leading edge blanking if there is any output drive.

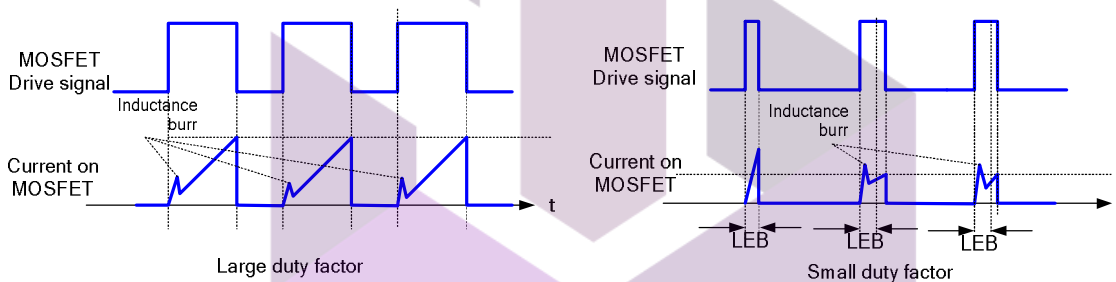

### 7. Over Voltage Protection

The output is shutdown if voltage at  $V_{cc}$  exceeds the threshold value and this state is kept until the circuit is powered on reset.

### 8. Overload Protection

FB voltage increases if there is overload and the output is shutdown when FB voltage is up to the feedback shutdown voltage. This state is kept until the circuit is powered on reset.

### 9. Cycle By Cycle Peak Current Limit

During each cycle, the peak current value is decided by the comparison value of the comparator, which will not exceed the peak current limited value to guarantee the current on MOSFET will not be larger than the rating current. The output power will not increase if the current reaches the peak value to limit the max. output power.

The output voltage decreases and FB voltage increases if there is overload and corresponding protection occurs.

### 10. Primary winding over current protection

If secondary diode is short, or the transformer is short, this protection will occur. At this time, once it is over current in spite of the leading edge blanking (L.E.B) time, protection will begin after 350ns, and is active for every



cycle. When the voltage on the current sense resistor is 1.7V, this protection will occur and the output is shut down. This state is kept until the under voltage occurs, and the circuit will start.

### 11. Thermal Shutdown

If the circuit is over temperature, the over temperature protection will shut down the output to prevent the circuit from damage. This state is kept until it quit the temperature protection, and the circuit will start.

## TYPICAL APPLICATION CIRCUIT

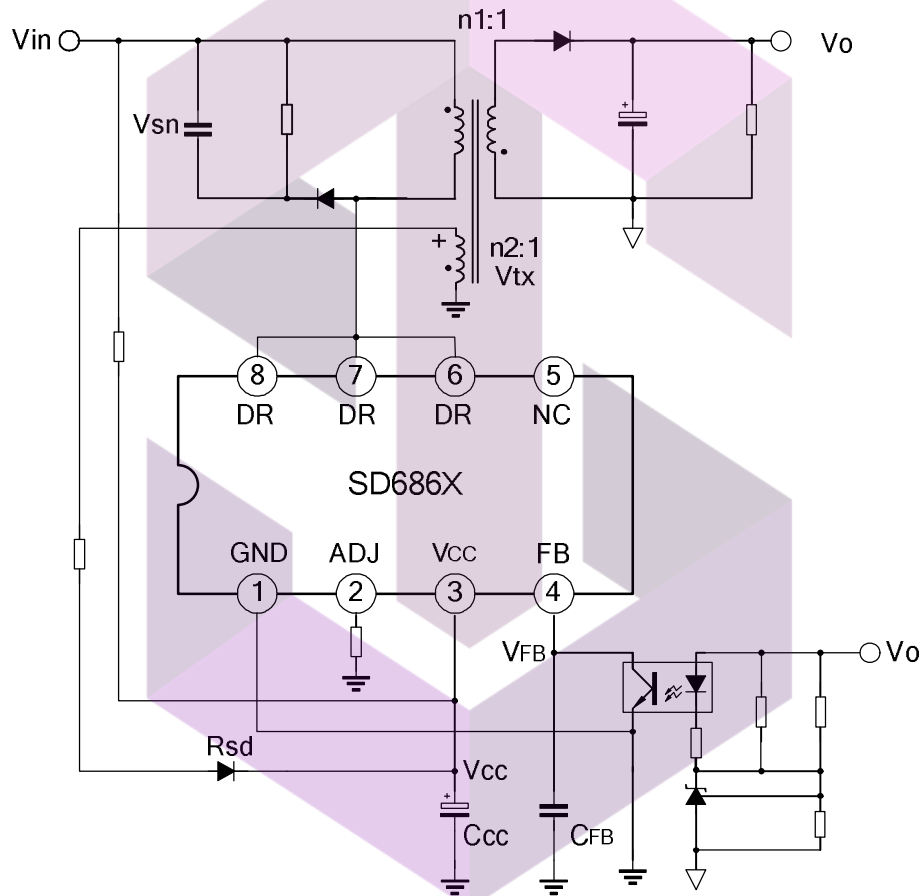

Note:

The circuit and parameters are for reference only, please set the parameters of the real application circuit based on the real test.

SKYTECH  
تهیه و توزیع قطعات الکترونیک

PACKAGE OUTLINE

DIP-8-300-2.54

UNIT: mm

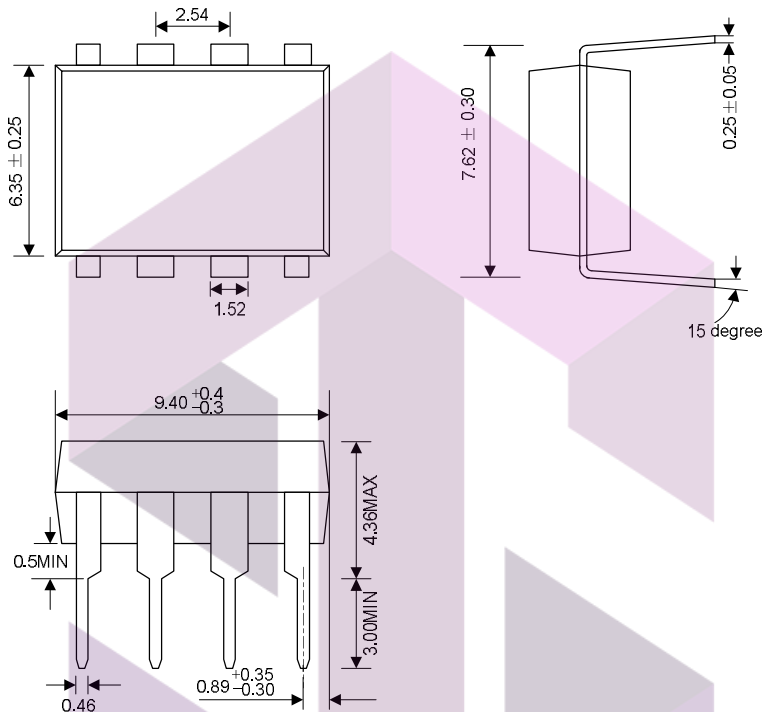

**MOS DEVICES OPERATE NOTES:**

Electrostatic charges may exist in many things. Please take following preventive measures to prevent effectively the MOS electric circuit as a result of the damage which is caused by discharge:

- The operator must put on wrist strap which should be earthed to against electrostatic.
- Equipment cases should be earthed.
- All tools used during assembly, including soldering tools and solder baths, must be earthed.
- MOS devices should be packed in antistatic/conductive containers for transportation.

**Disclaimer :**

- Silan reserves the right to make changes to the information herein for the improvement of the design and performance without further notice! Customers should obtain the latest relevant information before placing orders and should verify that such information is complete and current.
- All semiconductor products malfunction or fail with some probability under special conditions. When using Silan products in system design or complete machine manufacturing, it is the responsibility of the buyer to comply with the safety standards strictly and take essential measures to avoid situations in which a malfunction or failure of such Silan products could cause loss of body injury or damage to property.
- Silan will supply the best possible product for customers!